



Unenclosed
13.2×15.3×18



Wash tight
17.5×15×20

Features

- Superminiature, heavy power.
- Low coil power consumption.
- Switching current up to 20A.
- PC board mounting.
- Suitable for household appliances, electrical equipment, automation system, and automobile industry application.

Ordering Information

4117 C S 10 DC12V 1.0
1 2 3 4 5 6

1 Part number: 4117	4 Contact Current: 10:10A; 20:20A
2 Contact arrangement: A:1A;B:1B;C:1C;U:1U;V:1V;W:1W	5 Coil rated Voltage(V): DC:3,5,6,9,12,18,24
3 Enclosure: S: Wash tight; Z: Flux proof O: Unenclosed	6 Coil power: 1.0:1.0W; 1.1:1.1W; 1.2:1.2W

Contact Data

Contact Arrangement	1A(SPSTNO) 1B(SPSTNC) 1C(SPDT(B-M)) 1U(SPSTNODM) 1V(SPSTNCDB) 1W(SPDTNC-NO)	
Contact Material	AgSnO ₂ AgNi	
Contact Rating (Resistive)	1A,1B,1C: 10A/120VAC,28VDC 20A/14VDC 1U,1V,1W: 2×10A/120VAC,28VDC 2×20A/14VDC	
Max. Switching Power	1C: 280W 1200VA 1W: 2×280W 2×1200VA	
Max. Switching Voltage	30VDC 277VAC	Max. Switching Current:20A
Voltage Drop(Initial)	Typ. 50mV(at 10A)	Item 4.12 of IEC 61810-7
Operation Life	Electrical	1×10 ⁵ Item 4.30 of IEC 61810-7
	Mechanical	1×10 ⁷ Item 4.31 of IEC 61810-7

- CAUTION:** 1.For the intermediate current, it only applies to the room temperature.
2.For the open type relays, the min. switching current and min. switching voltage is 100mA/6VDC.

Coil Parameter

Dash numbers	Coil voltage VDC		Coil resistance Ω ±10%	Pick-up voltage VDC(max) (75%of rated voltage)	Drop-out voltage VDC(min) (10% of rated voltage)	Coil power W	Operate time ms	Release time ms
	Rated	Max.						
003-1000	3	3.9	9	2.25	0.3	1.0	≤10	≤5
005-1000	5	6.5	25	3.75	0.5			
006-1000	6	7.8	36	4.50	0.6			
009-1000	9	11.7	85	6.75	0.9			
012-1000	12	15.6	145	9.00	1.2			
018-1000	18	23.4	324	13.5	1.8			
024-1000	24	31.2	576	18.0	2.4			
012-1100	12	15.6	130.9	9.00	1.2	1.1	≤10	≤5
024-1100	24	31.2	523.6	18.0	2.4			
012-1200	12	15.6	120	9.00	1.2	1.2	≤10	≤5

- CAUTION:** 1.The use of any coil voltage less than the rated coil voltage will compromise the operation of the relay.
2.Pickup and release voltage are for test purposes only and are not to be used as design criteria.

Characteristics

Insulation Resistance	100M Ω min (at 500VDC)	Item 4.11 of IEC 61810-7
Dielectric Strength Between Contacts	50Hz 750V	Item 4.9 of IEC 61810-7
Between Contact and Coil	50Hz 1500V	Item 4.9 of IEC 61810-7
Shock Resistance	98m/s ² 11ms	Item 4.26 of IEC 61810-7
Vibration Resistance	10Hz~40Hz Double amplitude 1.27mm	Item 4.28 of IEC 61810-7
Terminals Strength	10N	Item 4.24 of IEC 61810-7
Ambient Temperature	-40 $^{\circ}$ C~105 $^{\circ}$ C	
Relative Humidity	5% to 85%	Item 4.16 of IEC 61810-7
Mass	9g (Unenclosed) 12g	Item 4.7 of IEC 61810-7

Dimensions

mm

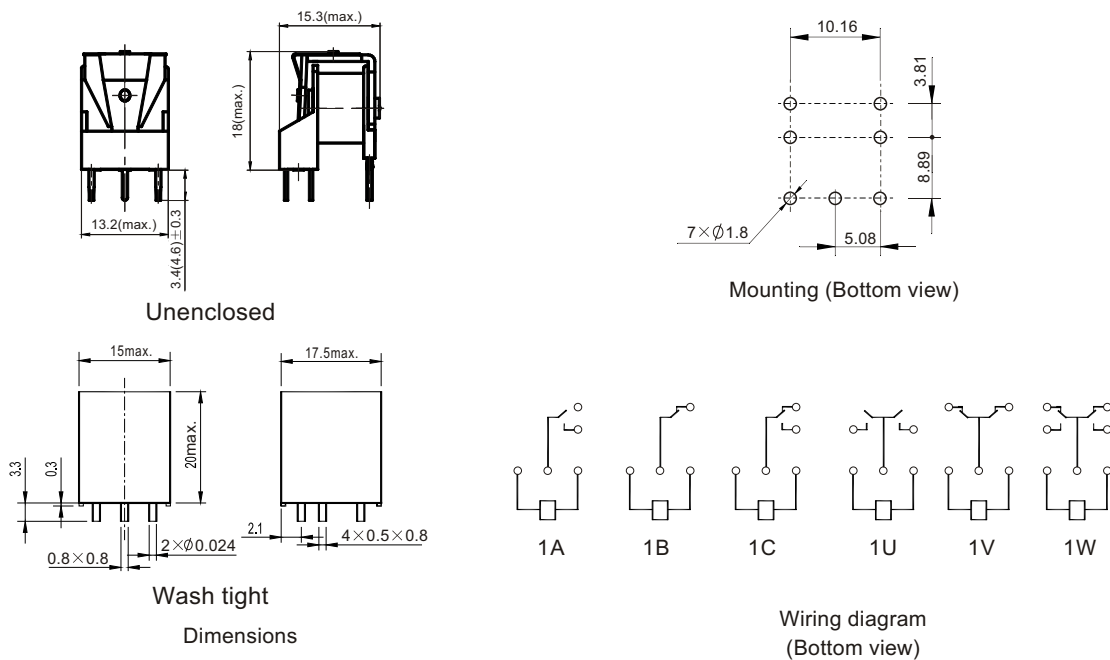

CAUTION: In case of no tolerance shown in outline dimension: outline dimension \leq 1mm, tolerance should be \pm 0.2mm; outline dimension >1mm and \leq 5mm, tolerance should be \pm 0.3mm; outline dimension >5mm, tolerance should be \pm 0.4mm.

Reference Data

