



34.5×32.5×34

NVF4-6

Features

- Small size.
- Contact load capacity up to 150A.
- Suitable for automobile.
- PC board mounting and direct insert mounting available.

Ordering Information

NVF4-6a C Z 100 a S D DC12V
 1 2 3 4 5 6 7 8

1 Part number: NVF4-6,
 NVF4-6a(Metal Bracket)
 2 Contact arrangement: A:1A; C:1C
 3 Enclosure: Z: Flux proof
 4 Contact Current: 50A,100A,150A
 5 Terminals: a: plug in type; b: PCB type

6 Contact Material: S: AgSnO₂
 7 Coil transient suppression: D: with diode
 R: with resistance
 NIL: standard
 8 Coil rated voltage(V): DC:12,24

Contact Data

Contact Arrangement	1A(SPSTNO) 1C(SPDT(B-M))		
Contact Material	AgSnO ₂		
Contact Rating (Resistive)	1A		1C
	50A/24VDC 100A,150A/12VDC		NO: 100A,150A/12VDC;50A/24VDC NC: 80A,100A/12VDC;50A/24VDC
Max. Switching Power	1800W		
Max. Switching Voltage	75VDC		Max. Switching Current:150A
Voltage Drop(Initial)	Typ. 50mV(at 10A)		Item 4.12 of IEC 61810-7
Operation	Electrical	1×10 ⁵ Item 4.30 of IEC 61810-7	
	Mechanical	1×10 ⁷ Item 4.31 of IEC 61810-7	

Coil Parameter

Dash numbers	Coil voltage VDC		Coil resistance Ω ±10%		With Suppression Resistive	Pick-up voltage VDC(max) (65%of rated voltage)	Drop-out voltage VDC(min) (10% of rated voltage)	Coil power W	Operate time ms	Release time ms
	Rated	Max.	Without Resistive	With Resistive						
012-2900	12	15.6	50	47	680	7.8	1.2	2.9	≤10	≤5
024-2900	24	31.2	195	182	2700	15.6	2.4			

CAUTION: 1.The use of any coil voltage less than the rated coil voltage will compromise the operation of the relay.
 2.Pickup and release voltage are for test purposes only and are not to be used as design criteria.

Characteristics

Insulation Resistance ¹⁾	100MΩ min (at 500VDC)	Item 4.11 of IEC 61810-7
Dielectric Strength ¹⁾ Between Contacts Between Contact and Coil	50Hz 750V 50Hz 1000V	Item 4.9 of IEC 61810-7 Item 4.9 of IEC 61810-7
Shock Resistance	147m/s ² 11ms	Item 4.26 of IEC 61810-7
Vibration Resistance	10Hz~40Hz Double amplitude 1.5mm	Item 4.28 of IEC 61810-7
Terminals Strength	Terminal retention(pull & push):≥100N Terminal resistance to bending(front & side):≥10N	Item 4.24 of IEC 61810-7
Ambient Temperature	-40℃~125℃	Item 4.11 of IEC 61810-7
Relative Humidity	5% to 85%	Item 4.16 of IEC 61810-7
Mass	65g	Item 4.7 of IEC 61810-7

Note: 1). When testing, coil terminals should be connected, If coil transient suppression is installed in relay.

Dimensions

mm

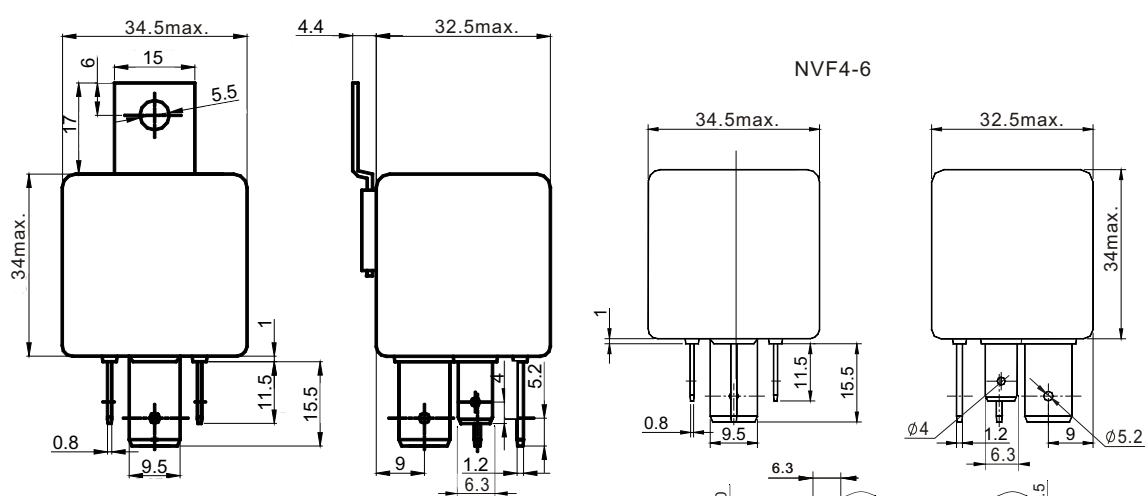

NVF4-6a

Dimensions

PCB type

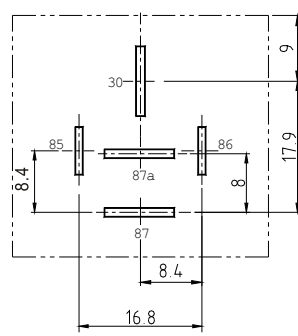

Plug in type

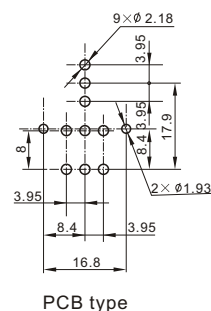

PCB type

Mounting (Bottom view)

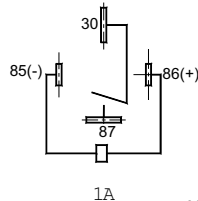

1A

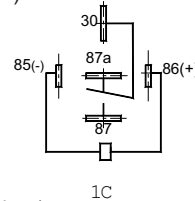

1C

Wiring diagram (Bottom view)

CAUTION: In case of no tolerance shown in outline dimension: outline dimension ≤1mm, tolerance should be ±0.2mm; outline dimension >1mm and ≤5mm, tolerance should be ±0.3mm; outline dimension >5mm, tolerance should be ±0.4mm.